



Valves

Handling the world's dry bulk solids®



VORTEX® VAC-SLIDE™ GATE

The Vortex® VAC-Slide™ Gate is specifically designed to handle dry bulk solids in gravity flow or vacuum conveying systems. A full flow orifice provides unrestricted conveying of material with no disk or ledges to impede flow or cause material bridging. The VAC-Slide™ Gate is designed to eliminate problems associated with typical butterfly valves and knife gates, increasing production, while decreasing labor and equipment costs.

Vortex® VAC-Slide™ Gate Features

- Smooth, Unobstructed Bore for Unrestricted Flow of Material
- Seal Protected from Abrasion
- Access Ports for In-service Seal Adjustment
- Easy Installation and Maintenance



Valve Specifications

Size/Bore Options	75mm to 150mm (3 to 6 inch) Diameter
Media	Pellets, Granulars
Connection	ANSI, DIN, JIS Wafer Pattern
Media Temperature	Up to 82°C (180°F) continuous to 121°C (250°F) intermittent service
Media Pressure	Up to 15 in/Hg, -1MPa
Material Construction	Hard Polymer Flange, Painted Carbon Steel Support Frame, and Stainless Steel Blade
Seal/Seat Material Options	Braided Teflon
Drive/Actuation Options	Double Acting Air Cylinder with Solenoid Operated Air Control Valve
Position Confirmation	Magnetic Reed Switch
Compliance/Approvals	CE
Industry Use	Plastics

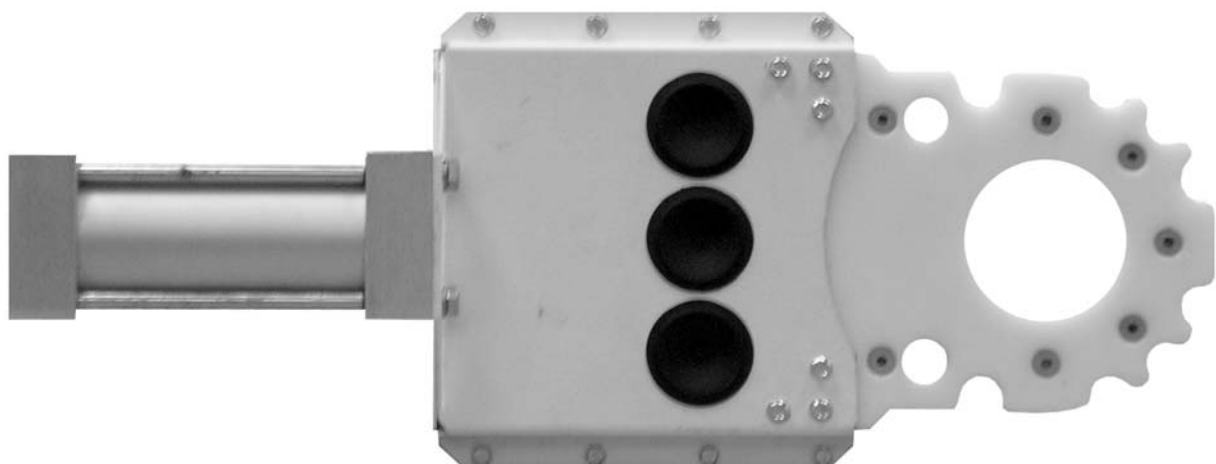

VORTEX® VAC-SLIDE™ GATE DIMENSIONAL INFORMATION

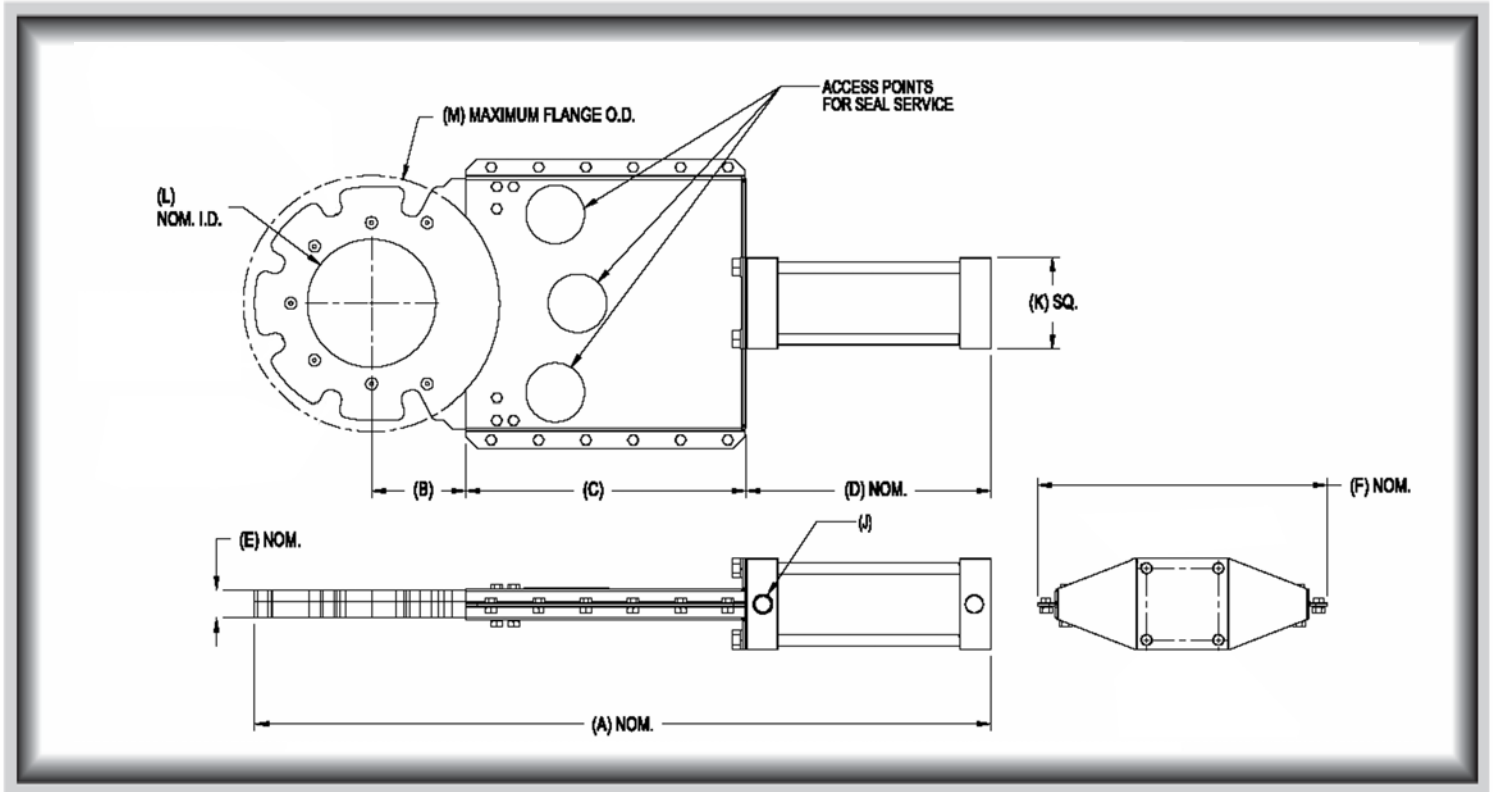

MODEL	A	B	C	D	E	F	J	K	L	M	O	P	Outlet (Nom ID)	WT (Lbs)
VRA75	20 7/8	3 1/4	7 3/8	7 1/4	1 1/4	8 1/4	G 3/8	2 7/8	2 3/4	7 5/8	3/4	6	3 1/16	12
VRA100	26 1/4	3 1/4	10 5/8	8 1/4	1 1/4	11	G 3/8	3 1/2	3 3/4	9	3/4	7 1/2	4 1/16	18
VRA125	30 1/8	3 3/4	11 5/8	10	1 1/4	12	G 1/2	4 1/8	4 3/4	10 1/2	7/8	8 1/2	5 1/16	27
VRA150	33 1/8	4 1/4	12 5/8	11	1 1/4	13	G 1/2	4 1/8	5 3/4	11 1/2	7/8	9 1/2	6 1/16	31

Dimensions are in inches, Information subject to change without notice.

MODEL	A	B	C	D	E	F	J	K	L	M	O	P	Outlet (Nom ID)	WT (Kg)
VRA75	530	83	187	184	32	210	G 3/8	73	70	194	19	152	78	5
VRA100	667	83	270	210	32	279	G 3/8	89	95	229	19	191	103	8
VRA125	765	95	295	254	32	305	G 1/2	105	121	267	22	216	128	12
VRA150	841	108	321	279	32	330	G 1/2	105	146	292	22	241	154	14

Dimensions are in mm, Information subject to change without notice.